

UNLESS OTHERWISE SPECIFIED DIMENSIONS ARE IN INCHES FRACTIONS DECIMALS ANGLES ± 1/64 ± .005 ± 0°30'

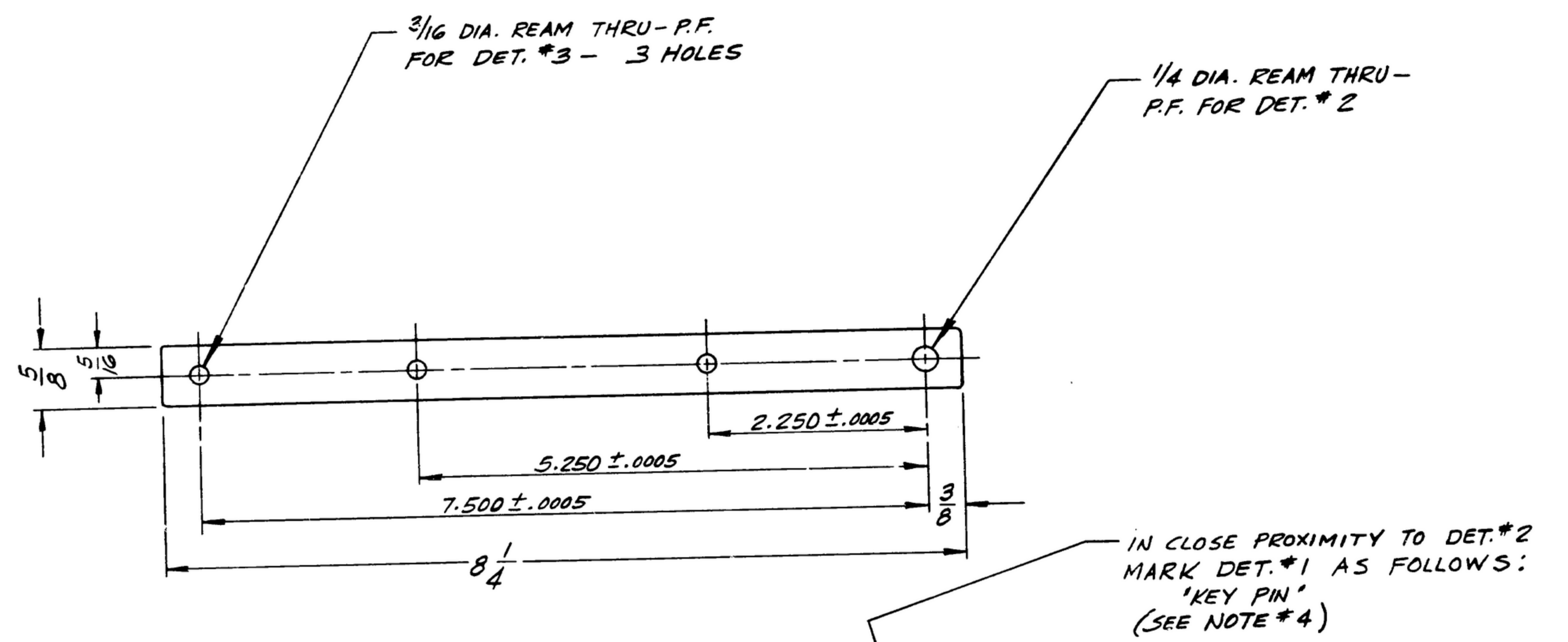

- NOTES:
- GAGE TO BE MADE PER MIL-G-13451 (SIG. C.)
 - MECHANICAL FITS SHALL BE PER SPEC MIL-G-10944.
 - MATERIAL SPECS. PER QQ-5-00778 (ARMY ORD.) CLASS FS-A2
 - METAL STAMP OR ENGRAVE USING 1/8" GOTHIC CHARACTERS.
 - WEAK ALL UNNECESSARY SHARP EDGES & CORNERS.
 - ALL SCREW THREADS ARE PER DEPT. OF COMM. HANDBOOK #H-28
 - PROTECTIVE FINISH SHALL BE APPLIED TO THE NON-FUNCTIONING, NON LOCATING, & NON GAGING SURFACES. BLACK PREFERRED PER MIL-G-10944.
 - STEEL, BAR, HOT ROLLED (NORMALIZED) FS-1010 TO FS-1095 PER SPEC. QQ-5-633
 - THIS GAGE WILL CHECK DWG. #SM-D-

MARKING: SEE NOTE #4

R-390 A/URR
LOCATION PATTERN OF
PANEL MTG. SLOTS
SIG. C. INSP.
57060
MFRS. NAME OR SYM.

③ ② ① GAGE BAR - 1 REQ'D.
STEEL - SEE NOTE #8

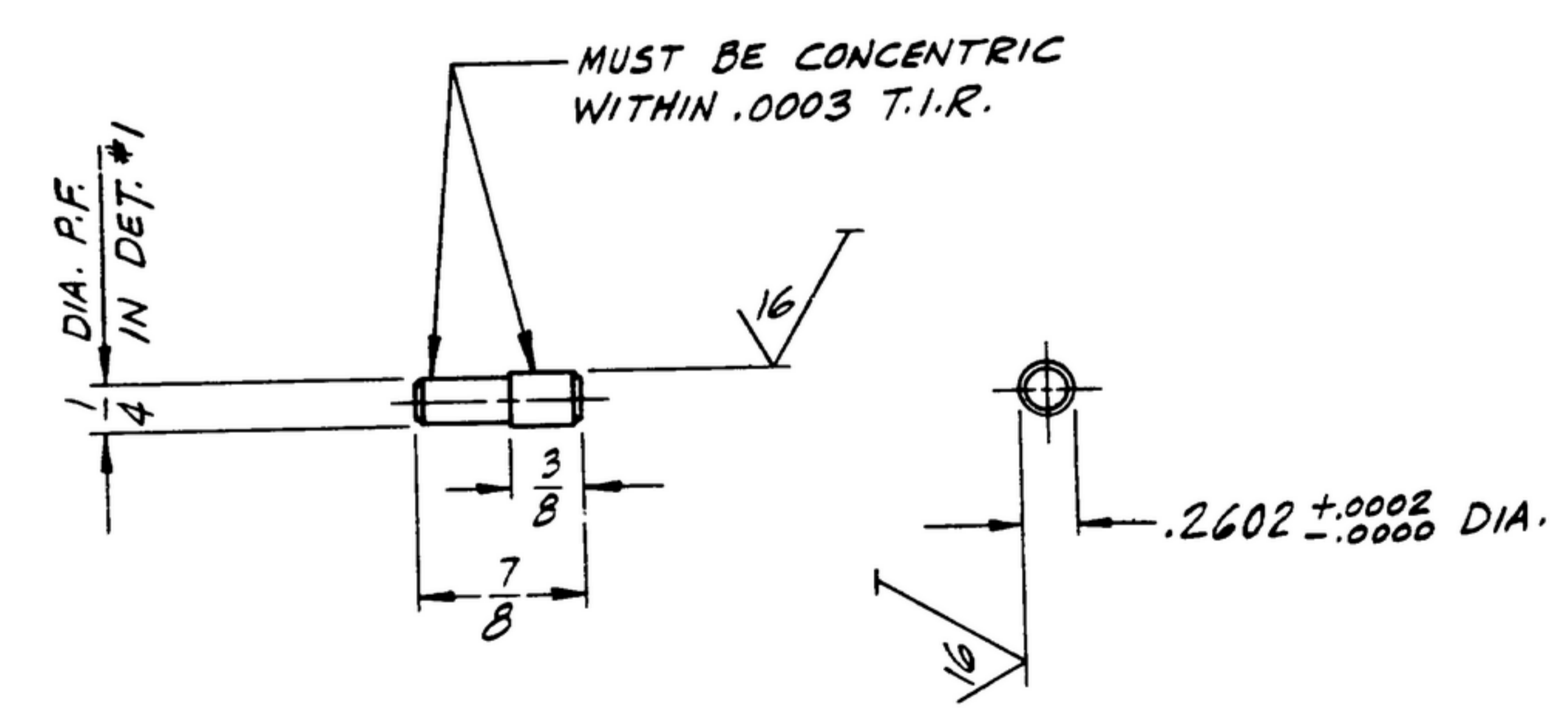

② GAGE PIN - 1 REQ'D.
STEEL - SEE NOTE #3
ROCKWELL "C" 62 MIN.

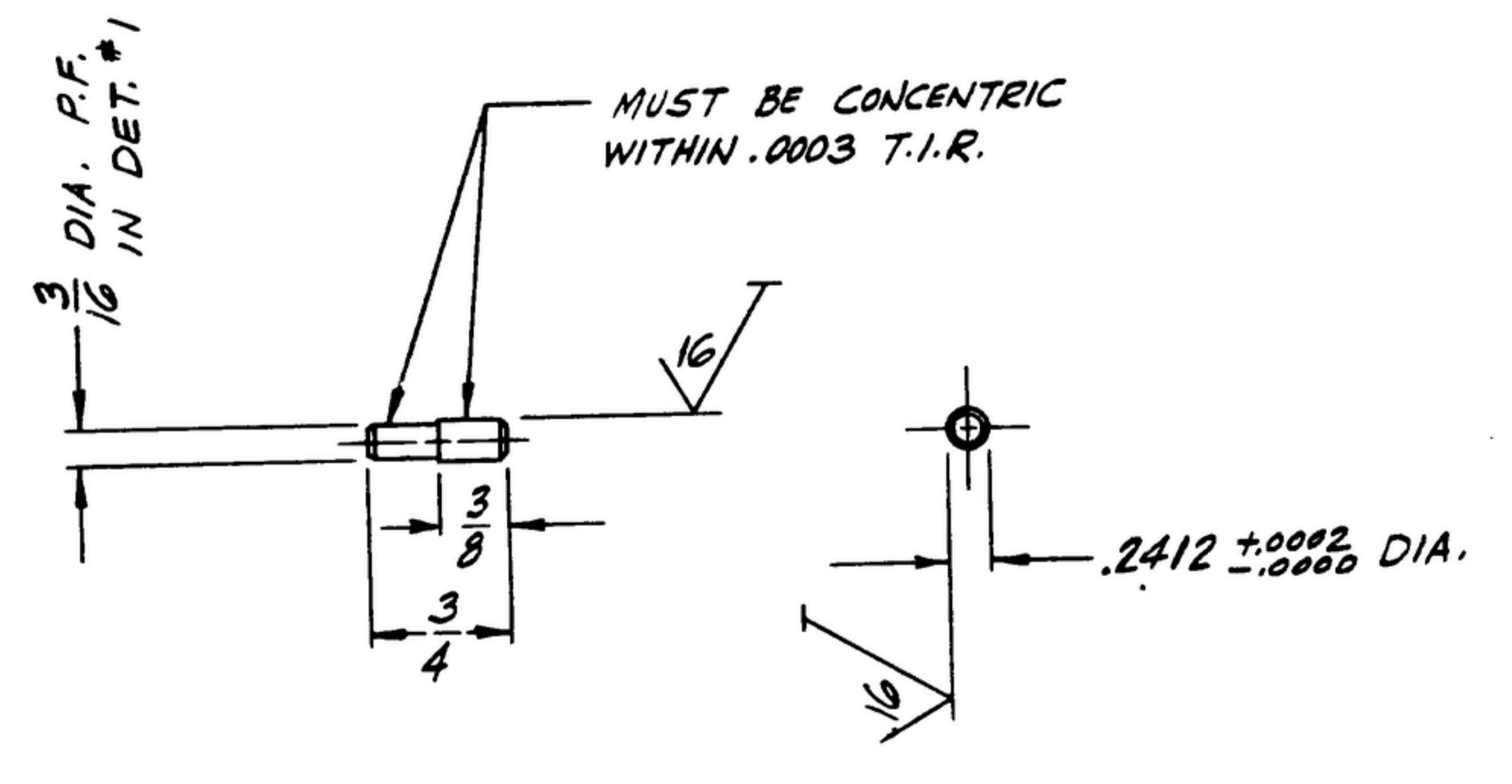

③ GAGE PIN - 3 REQ'D.
STEEL - SEE NOTE #3
ROCKWELL "C" 62 MIN.

DET. NO.	REQD.	PART NO.	DESCRIPTION	MATL.	FINISHED SIZE	NOTE
3	3	-3	GAGE PIN	STEEL	1/4 DIA. x 3/4 LG.	3
2	1	-2	GAGE PIN	STEEL	3/32 DIA. x 1/8 LG.	3
1	1	SM-D-57060-1	GAGE BAR	STEEL	5/8 x 7/8 x 8 1/4	8

UNLESS OTHERWISE SPECIFIED DIMENSIONS ARE IN INCHES FRACTIONS DECIMALS ANGLES ± 1/64 ± .005 ± 0°30'		MOTOROLA INC.		GAGE TO CHECK LOCATION PATTERN OF PANEL MOUNTING SLOTS. R-390 A/URR	DEPARTMENT OF THE ARMY SIGNAL CORPS ENGINEERING LABORATORIES FORT MONMOUTH NEW JERSEY
DRAWN J.MACH		REVIEWED XXX			
DATE 9-11-58		APPROVED mH		SM-D-57060	
CHECKED EdL.		DATE 11 SEPT. 1958			
APPLICATION		APPROVED R J Y		SCALE FULL	